

SPORTELLI E CASSETTI

Doors and drawers



SOMMARIO

Contents

CARATTERISTICHE 5
Features

SPORTELLI 8
Doors

CASSETTI E CASSETTIERE 16
Drawers and drawer-units

TRAMOGGE PER FONDI CAFFÈ 28
Hoppers for coffee-grounds

CONTENITORI PER VUOTI 30
Waste containers

La soluzione globale Ronda di cassetti e sportelli in acciaio inox o inox/vetro per celle frigorifere e banchi neutri, concepita espressamente per i professionisti del food-beverage. Una gamma completa che garantisce la massima praticità, robustezza e facilità di manutenzione: dalla scelta dei materiali all'ingegneria dei componenti, risultato di ricerche in laboratorio e rigorosi test di resistenza. Una gamma con tutta l'eleganza dello stile italiano, linee essenziali e forme innovative in sintonia con le ultime tendenze dell'arredamento.

Ronda's global solution for drawers and doors in stainless steel or in stainless steel/glass for cold stores or standard counters, conceived expressly for food and beverage professionals. A complete range that guarantees maximum practicality, sturdiness and ease of maintenance: from the choice of materials to the engineering of components, the result of laboratory research and accurate resistance testing. A range with all the elegance of Italian style, essential lines and innovative shapes that follow the latest trends in furnishing.

LEGENDA

Key

a(+1) b(+1)	(0,+1) Tolleranza consigliata per il foro banco (mm) (0,+1) Suggested tolerance for the counter hole (mm)
x - y	Dimensioni esterne della cornice Dimensions of the front panel including the frame
e - f	Dimensioni interne della cassa Internal dimensions of the container
g	Passaggio utile con apertura 90° Useful width 90°
g1	Passaggio utile con apertura 175° Useful width 175°
h	Altezza cassa interna Height of the inner container
h1	Altezza cassa interna 1° cassetto Height of the inner container 1st drawer
h2	Altezza cassa interna 2° cassetto Height of the inner container 2nd drawer
h3	Altezza cassa interna 3° cassetto Height of the inner container 3rd drawer
l	Profondità totale dell'articolo da filo banco Total depth of the item from the counter front
s	Sporgenza esterna da filo banco External projection from the counter front
u	Altezza utile interna Useful internal height
u1	Altezza utile interna del 1° cassetto Useful internal height 1st drawer
u2	Altezza utile interna del 2° cassetto Useful internal height 2nd drawer
u3	Altezza utile interna del 3° cassetto Useful internal height 3rd drawer
z	Profondità totale della cornice da filo banco Total depth of the frame from the counter front

Misure espresse in mm / Measurements in mm

Il freddo, a portata di mano. Prestazioni serie A1 con temperatura cella a +5°C

Cold on hand.
Series A1 performance with cell temperature +5 C

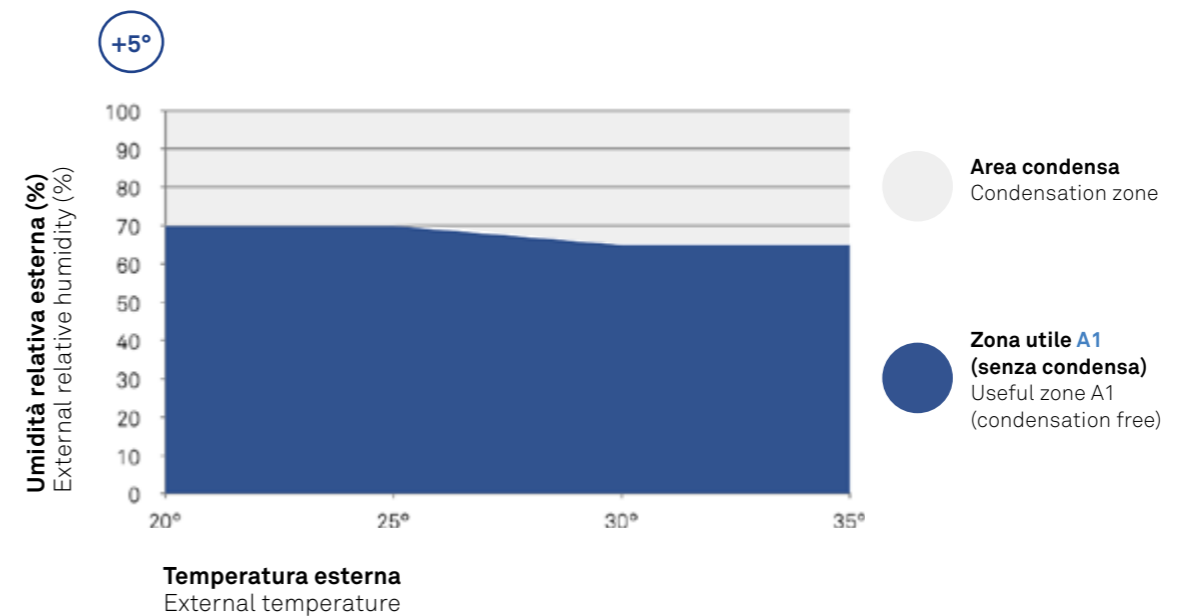

**Nuovo spessore cassa
maggiorato in tutti i cassetti
Ronda: acciaio 8/10.**

New increased thickness in all
Ronda drawers: 8/10 steel.

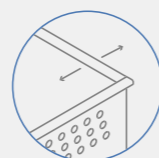

Nuovo spessore cassa 8/10
New box thickness 8/10

**Nel corso del 2019 Ronda ha sostituito
il sistema poliuretano espanso
HFC a bassa viscosità con il nuovo
espandente di quarta generazione
HFO Solstice® LBA a basso GWP (1).**

**Questo nuovo sistema è privo di CFC,
HCFC e HFC ed è classificato classe
F secondo la normativa Europea EN
ISO 11925 e UNI EN 13501.**

**Test di laboratorio dimostrano
che Solstice® LBA garantisce
un miglioramento in termini
di efficienza energetica,
superiore al 3%, rispetto a sistemi
HFC o a schiume a base acquosa.**

During 2019 Ronda has replaced
the HFC low viscosity expanded
polyurethane system with the new
fourth generation expanding HFO
Solstice ® LBA with low GWP (1).

This new system is CFC, HCFC,
and ranked class F in the European
standard EN ISO 11925 and UNI EN
13501.

Laboratory tests have demonstrated
that Solstice ® LBA ensures improved
energy efficiency, 3% better than HFC
systems or water based foams.

SPORTELLI / DOORS

**Prestazioni termiche garantite fino a
condizioni ambientali di 20°C a 70% UR
(Umidità Relativa), 35°C a 65% UR con
temperatura cella frigorifera di 5°C.
Forza di apertura sportelli pari a 3,4 kg.
Prova di durata per 160.000 cicli con
carico di 2 kg.**

Thermal performance guaranteed up to
environmental conditions of 20°C with 70%
RH (relative humidity), and 35°C with 65% RH
with the refrigerator cell temperature at 5°C.
Door opening force of 3.4 kg. Duration test for
160.000 cycles with a 2 kg load.

CASSETTIERE / DRAWER-UNITS

**Prova di durata per 80.000 cicli con carico
incrementale fino a max. 30 kg in base alle
dimensioni del cassetto. Prestazioni termiche
garantite fino a condizioni ambientali di
20°C a 70% UR (Umidità Relativa), 35°C
a 65% UR e velocità aria di 0,8 m/s con
temperatura cella frigorifera di 5°C.**

Duration test for 80.000 cycles with
incremental load up to 30 kg according to
the size of the drawer. Thermal performance
guaranteed under environmental conditions
of 20°C with 70% RH (relative humidity), and
35°C with 65% RH and an air speed of 0.8
m/s with refrigerator cell temperature at 5°C.

CONTENITORI / CONTAINERS

**Prova di durata per 50.000 cicli di apertura
e chiusura.
I contenitori vuoti possono avere la versione
“Ignifuga” grazie all’inserimento in un
involucro in acciaio.**

Duration test for 50.000 opening and closing
cycles.
The containers can have the “fire-resistant”
version thanks to the insertion in a steel
casing.

CASSETTINI / SMALL DRAWERS

**Prova di durata in apertura e chiusura
per 40.000 cicli con carico di 11 kg.**

Duration test for 40.000 opening and closing
cycles with an 11 kg load.

TRAMOGGE / HOPPERS

**Prova di affidabilità con simulazione di colpi
su battifiltro per 1.000.000 cicli.
La durata del tubo battifiltro dipende dalla
condizione d'uso.**

Reliability test with simulation of blows on the
knock-out bar for 1.000.000 cycles.
The durability of the knock-out bar depends
on the conditions of usage.

Opzionale / On demand:

- 1) Installazione dello scrocco**
Closing latch installation
- 2) Installazione serratura opzionale**
Lock installation



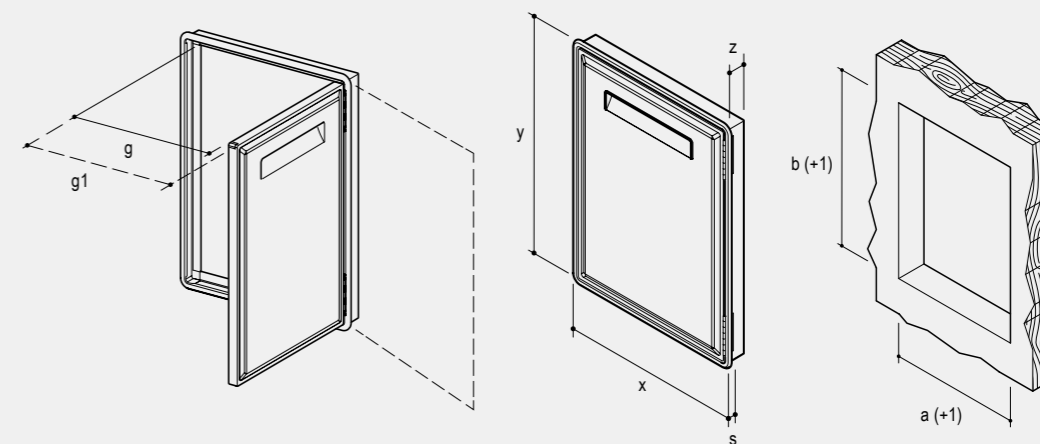

Articolo Item	Foro banco Counter hole		Dimensioni esterne ed interne External and internal size						Box
	a(+1)	b(+1)	x	y	z	s	g	g1	
AX11	442	305	469	332	50	13	379	398	2
AX11L ○	442	305	469	332	50	13	383	405	2
AX12	442	404	469	431	50	13	379	398	2
AX12L ○	442	404	469	431	50	13	383	405	2
AX13	442	442	469	469	50	13	379	398	2
AX14	502	442	529	469	50	13	439	458	2
AX15	602	442	629	469	50	13	539	558	2
AX16	442	502	469	529	50	13	379	398	2
AX17	442	602	469	629	50	13	379	398	2
AX17L ○	442	602	469	629	50	13	383	405	2
AX18	442	702	469	729	50	13	379	398	2



Apertura a destra
Right-hand opening



Apertura a sinistra
Left-hand opening

○ **Passaggio utile più largo e barra di rinforzo sul fondo**

Larger useful width and reinforcement bar at the bottom of the frame

Guarnizione magnetica di ricambio: disponibile su richiesta

Magnetic gasket: spare part available on demand

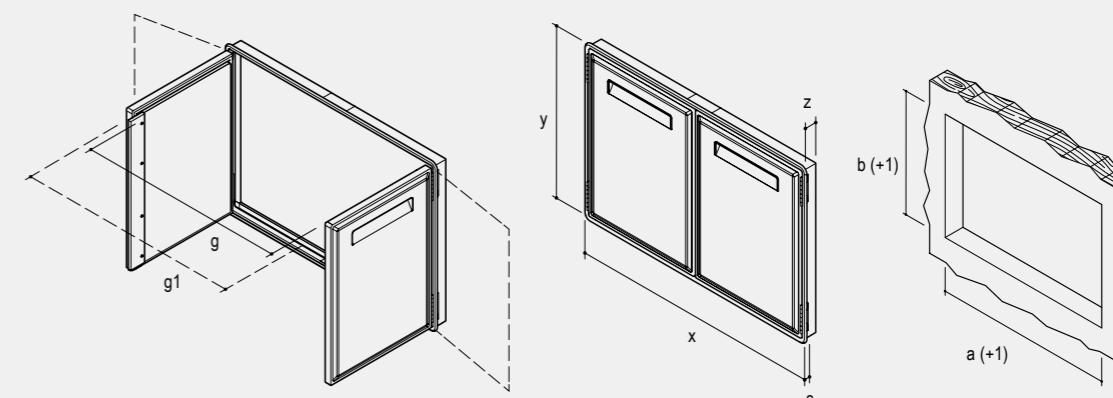

Articolo Item	Foro banco Counter hole		Dimensioni esterne ed interne External and internal size						Box
	a(+1)	b(+1)	x	y	z	s	g	g1	
AL16	878	502	905	529	50	13	796	834	2
AL17	878	602	905	629	50	13	796	834	2
AL18	878	702	905	729	50	13	796	834	2

Guarnizione magnetica di ricambio: disponibile su richiesta

Magnetic gasket: spare part available on demand

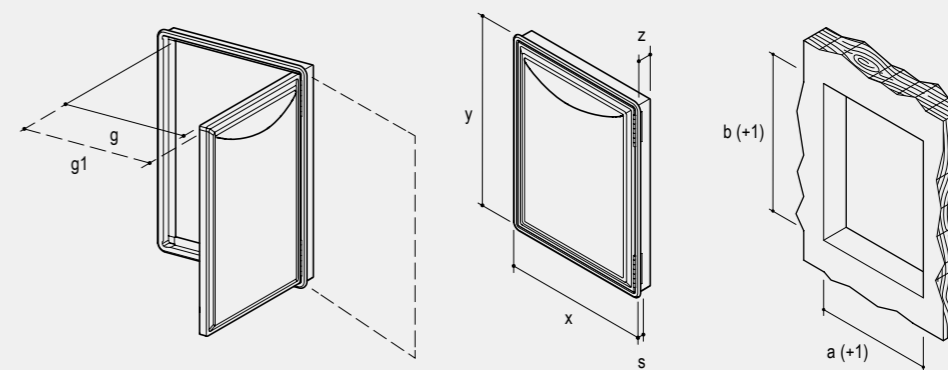

Articolo Item	Foro banco Counter hole		Dimensioni esterne ed interne External and internal size						Box
	a(+1)	b(+1)	x	y	z	s	g	g1	
AV17	442	602	469	629	50	38	389	398	2
AV18	442	702	469	729	50	38	389	398	2



Apertura a destra
Right-hand opening



Apertura a sinistra
Left-hand opening

Guarnizione magnetica di ricambio: disponibile su richiesta

Magnetic gasket: spare part available on demand

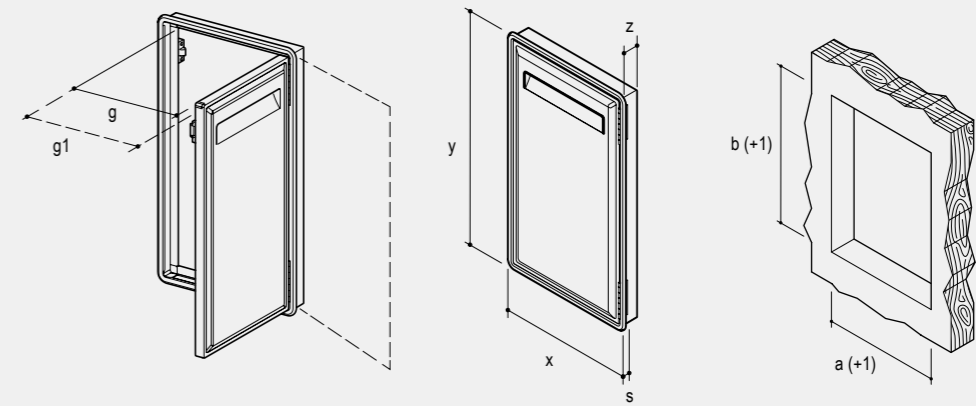

Articolo Item	Foro banco Counter hole		Dimensioni esterne ed interne External and internal size						Box
	a(+1)	b(+1)	x	y	z	s	g	g1	
ZBX17	442	602	469	629	50	13	379	398	2
ZBX20	354	502	381	529	50	13	305	308	1
ZBX21	354	638	381	665	50	13	305	308	1



Apertura a destra
Right-hand opening



Apertura a sinistra
Left-hand opening

**Gli sportelli neutri sono privi di guarnizione magnetica.
La chiusura meccanica a scrocco, fornito di serie, ne garantisce la chiusura.**

These doors are provided with a spring latch instead of the magnetic gasket, ensuring the mechanical closing.

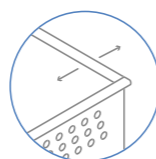

NUOVO SPESSORE CASSA 8/10
New box thickness 8/10

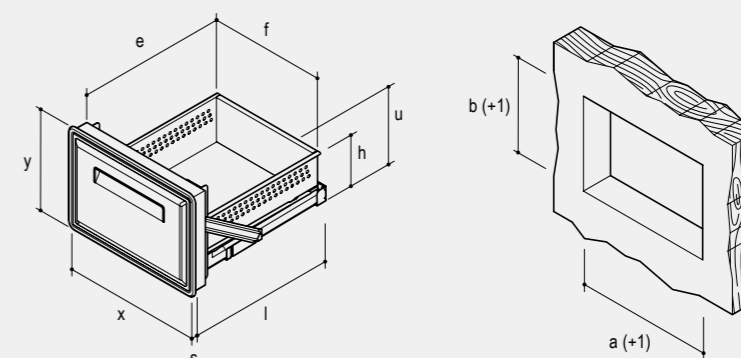

Articolo Item	Foro banco Counter hole		Dimensioni esterne ed interne External and internal size								Box
	a(+1)	b(+1)	x	y	e	f	h	l	u	s	
AK11	442	255	469	282	459	361	145	520	192	13	1
AK11C ○	442	255	469	282	397	361	145	458	192	13	1
AK12	442	305	469	332	459	361	145	520	242	13	1
AK12C ○	442	305	469	332	397	361	145	458	242	13	1
AK13	442	404	469	431	459	361	290	520	341	13	1
AK13C ○	442	404	469	431	397	361	290	458	341	13	1
AK14	442	442	469	469	459	361	290	520	379	13	1

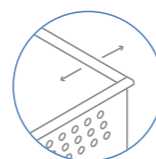

NUOVO SPESSORE CASSA 8/10
New box thickness 8/10

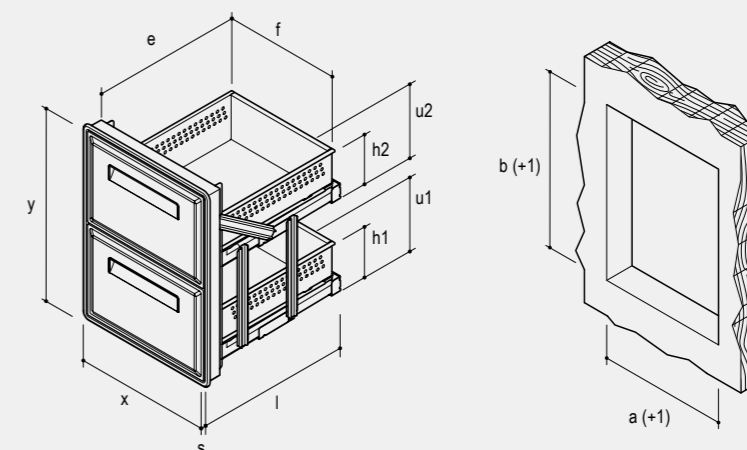

Articolo Item	Foro banco Counter hole		Dimensioni esterne ed interne External and internal size										Box
	a(+1)	b(+1)	x	y	e	f	h1	h2	l	u1	u2	s	
AM12	442	502	469	529	459	361	145	145	520	192	192	13	1
AM12C ○	442	502	469	529	397	361	145	145	458	192	192	13	1
AM13	442	602	469	629	459	361	145	145	520	242	242	13	1
AM13C ○	442	602	469	629	397	361	145	145	458	242	242	13	1

○ **Versione corta** Version with shorter slides

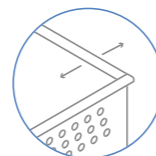

NUOVO SPESSORE CASSA 8/10

New box thickness 8/10

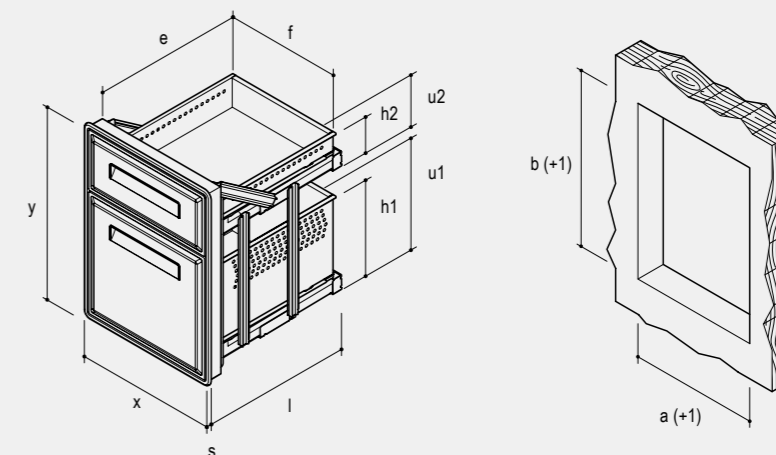

Articolo Item	Foro banco Counter hole		Dimensioni esterne ed interne External and internal size										Box
	a(+1)	b(+1)	x	y	e	f	h1	h2	l	u1	u2	s	
AZ11	442	602	469	629	459	361	290	96	520	342	143	13	1
AZ11C ○	442	602	469	629	397	361	290	96	458	342	143	13	1
AZ15	442	702	469	729	459	361	290	145	520	342	242	13	1
AZ15C ○	442	702	469	729	397	361	290	145	458	342	242	13	1

○ **Versione corta** Version with shorter slides

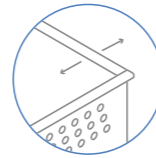

NUOVO SPESSORE CASSA 8/10
New box thickness 8/10

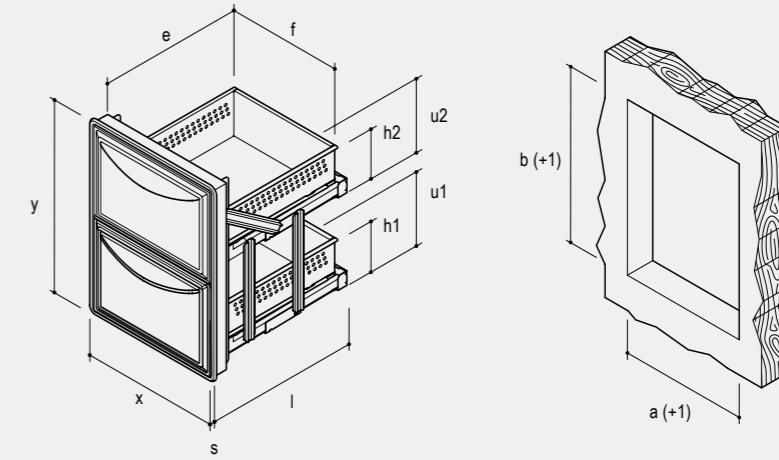

Articolo Item	Foro banco Counter hole		Dimensioni esterne ed interne External and internal size										Box
	a(+1)	b(+1)	x	y	e	f	h1	h2	l	u1	u2	s	
AMV13	442	602	469	629	459	361	145	145	520	242	242	38	1
AMV13C ○	442	602	469	629	397	361	145	145	458	242	242	38	1

○ **Versione corta** Version with shorter slides

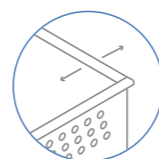
NUOVO SPESSORE CASSA 8/10

New box thickness 8/10

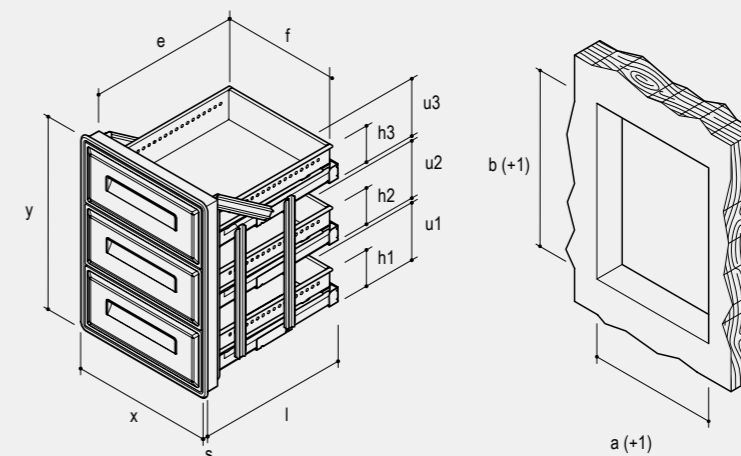

Articolo Item	Foro banco Counter hole		Dimensioni esterne ed interne External and internal size											Box	
	a(+1)	b(+1)	x	y	e	f	h1	h2	h3	l	u1	u2	u3		s
AR11	442	602	469	629	459	361	96	96	96	520	143	143	146	13	1
AR11C ○	442	602	469	629	397	361	96	96	96	458	143	143	146	13	1
AR12	442	702	469	729	459	361	145	96	96	520	242	143	146	13	1



AP272

Cassettino battifiltro per fondi di caffè
Small drawer with knock-out bar for coffee grounds



AP2812

Cassettino cassa con serratura e separatore a scomparti estraibile
Small cash drawer with lock and removable money tray



AP282

Cassettino per documenti con serratura e chiave numerata
Small document drawer with lock and numbered key



AP292

Cassettino base, multiuso
Small basic, multipurpose drawer

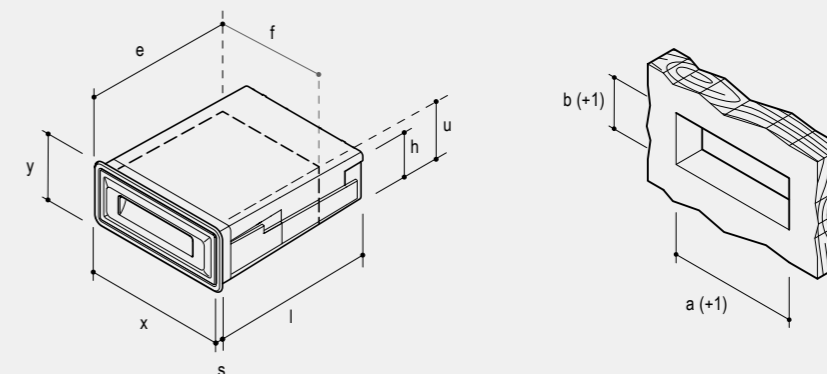

Articolo Item	Foro banco Counter hole		Dimensioni esterne ed interne External and internal size								Box
	a(+1)	b(+1)	x	y	e	f	h	l	u	s	
AP272	354	140	377	164	401	311	111	431	121	10	3
AP282	354	140	377	164	401	311	111	431	121	10	3
AP2812	354	140	377	164	401	311	111	431	121	10	3
AP292	354	140	377	164	401	311	111	431	121	10	3



Maniglia ergonomica sagomata, realizzata in materiale plastico ad alta resistenza, progettata per offrire una presa comoda, stabile e sicura durante l'uso quotidiano. Pratica e robusta, garantisce un'eccellente maneggevolezza e un'elevata durata nel tempo, anche in presenza di utilizzi frequenti e intensivi.

Ergonomically shaped handle made of high-resistance plastic, designed to provide a comfortable, stable, and secure grip during everyday use. Practical and durable, it ensures excellent handling and long-lasting performance, even under frequent and intensive use.

AG12

TRAMOGGIA SINGOLA PER FONDI CAFFÈ

Single hopper for coffee-grounds

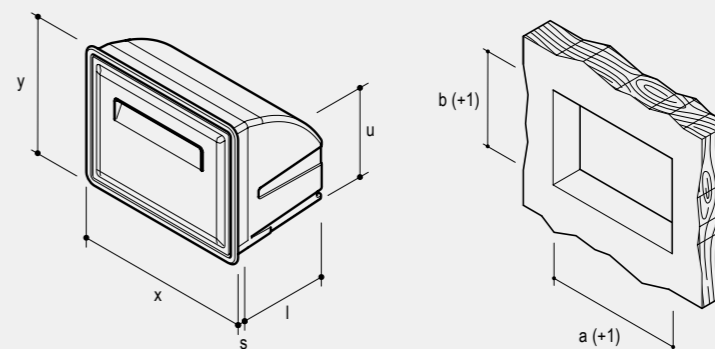

Articolo Item	Foro banco Counter hole		Dimensioni esterne ed interne External and internal size						Box
	a(+1)	b(+1)	x	y	l	u	s		
AG12	354	276	377	299	233	252	10	1	

AG14

TRAMOGGIA DOPPIA PER FONDI CAFFÈ

Double hopper for coffee-grounds

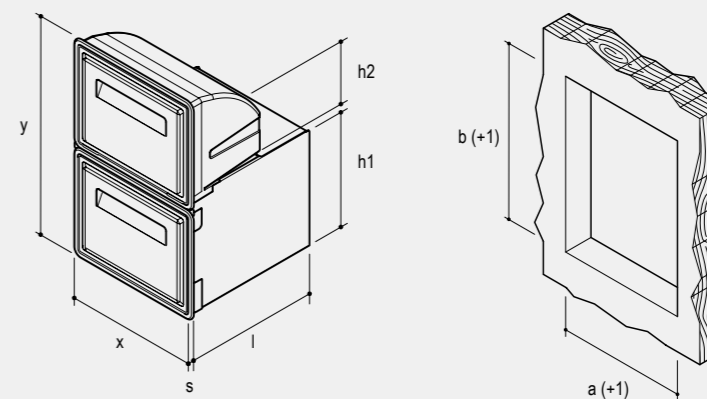

Articolo Item	Foro banco Counter hole		Dimensioni esterne ed interne External and internal size						Box
	a(+1)	b(+1)	x	y	h1	h2	l	s	
AG14	354	573	377	598	321	252	379	10	1

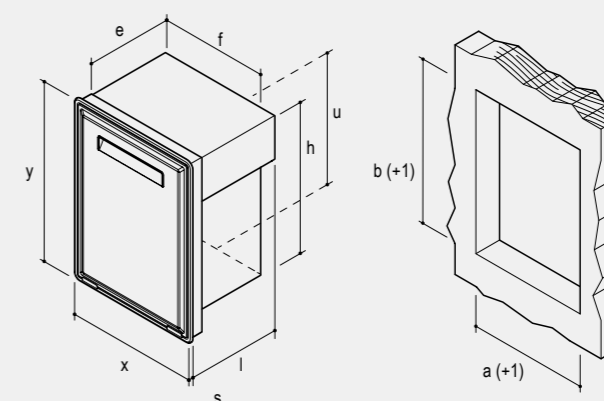

Articolo Item	Foro banco Counter hole		Dimensioni esterne ed interne External and internal size								Box	
	a(+1)	b(+1)	x	y	e	f	h	l	u	s		
AU11	442	502	469	529	291	361	328	323	439	13	1	
AU12	442	602	469	629	291	361	454	323	539	13	1	

CON CUFFIA
With steam protection hood

AU13	442	502	469	529	291	361	328	343	439	13	1
AU14	442	602	469	629	291	361	454	343	539	13	1

CONTENITORI PER RACCOLTA DIFFERENZIATA
Containers for separate waste collection

Articolo Item	Foro banco Counter hole		Capacità Capacity	Dimensioni esterne ed interne External and internal size								Box	
	a(+1)	b(+1)	Lt	x	y	e	f	h	l	u	s		
AU15	354	502	26	381	529	291	273	328	323	439	13	1	
AU16	354	638	39,5	381	665	291	273	496	323	576	13	1	



Adatti alla raccolta differenziata
Suitable for separate waste collection



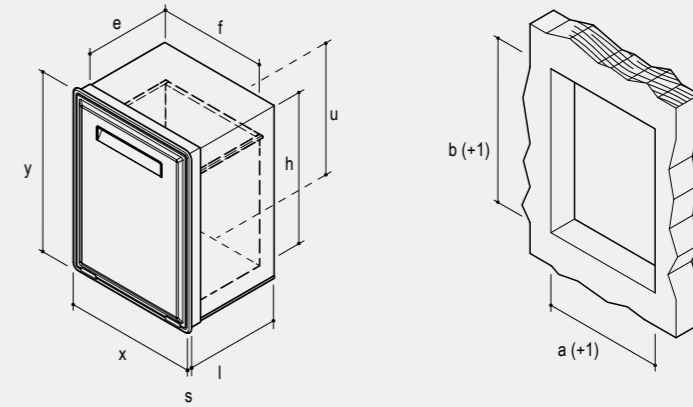

Articolo Item	Foro banco Counter hole		Dimensioni esterne ed interne External and internal size								Box		
	a(+1)	b(+1)	x	y	e	f	h	l	u	s			
AU111	442	502	469	529	291	361	328	343	439	13	1		
AU121	442	602	469	629	291	361	454	343	539	13	1		

CERTIFICAZIONI AZIENDALI

Company Certifications



I prodotti Ronda sono sottoposti a severe prove di affidabilità affinché, oltre alla bellezza e all'ergonomia, possano assicurare la più elevata resistenza e tenuta nel tempo. Tutte le fasi industriali dei prodotti Ronda avvengono sotto rigorosi controlli, dall'arrivo della materia prima fino all'imballaggio. Ronda opera secondo le normative e gli standard internazionali più severi. La Certificazione di Qualità ISO 9001 ottenuta dall'azienda è una garanzia ulteriore dell'affidabilità dei suoi prodotti e delle tecnologie impiegate per costruirli. Gli articoli sono stati provati con riferimento, ove applicabile, alla norma ISO 7170 "Furniture - Storage units - Determination of strength and durability".

Ronda utilizza imballi in polistirolo riciclati al 100% forniti da aziende virtuose nel riciclo e recupero del polistirolo con processo circolare ad alta efficienza.

Ronda applica, in ottemperanza al Reg.2023/2006/CE, dei protocolli interni per garantire buone pratiche di fabbricazione dei materiali ed oggetti destinati a venire a contatto con gli alimenti.

L'azienda si riserva il diritto di apportare modifiche e/o migliorie ai prodotti senza preavviso.

The company reserves the right to make changes and/or improvements to the products without prior notice.

Ronda products are subjected to very severe testing for reliability so that in addition to looks and ergonomics they also ensure maximum resistance and durability over time. All the industrial steps for Ronda products are conducted under strict controls, all the way from arrival of raw materials to packaging. Ronda operates under the strictest regulations and international standards. The company has been awarded ISO 9001 Quality Certification, providing a further guarantee for the reliability of its products and the production technologies applied. When applicable the items are tested with reference to standard ISO 7170 "Furniture - Storage units - Determination of strength and durability".

Ronda uses 100% recycled polystyrene packaging supplied by companies applying high standards for the re-use and recycling of polystyrene in a high efficiency circular process.

In compliance with Reg. 2023/2006/EC, Ronda applies internal protocols that ensure good manufacturing practice for materials and items meant to come into contact with foodstuffs.

MAESTRI DELL' ACCIAIO

Steel masters



Ronda è azienda leader in ricerca, design e innovazione nella produzione di componenti in acciaio inox per l'arredamento di bar e strutture di ristorazione professionale.

Interamente realizzati in Acciaio AISI 304, il materiale più igienico per eccellenza. I modelli Ronda sono resistenti alla corrosione, privi di qualunque rivestimento protettivo. Le loro superfici compatte garantiscono un'elevata rimozione batterica durante i cicli di pulitura.

Ronda is a leading company in research, design and innovation for the production of stainless steel units for equipping bars and professional catering facilities.

Ronda products are completely manufactured in AISI 304 stainless steel, the absolute most hygienic material. They are resistant to corrosion & free from surface porosity, so they don't need any protective coating and grant elevated bacterial removal during cleaning cycles.

