

**VASCHE, KIT CARAPINA E ACCESSORI PER IL GELATO**

Basins, Carapina box kit and Accessories for ice cream

**VG**



**La Serie VG comprende vaschette per il gelato, impilabili, di diverse misure e capacità, kit carapina gelato e accessori. In particolare, abbiamo realizzato un bordo progettato per agevolare la presa, rendendo i contenitori facili da maneggiare e pulire. Funzionali per l'inserimento negli armadi frigo e per l'esposizione nelle vetrine, sono costruiti in acciaio Inox 18/10 AISI 304 idoneo alla conservazione del gelato secondo la direttiva UE n. 1935/2004 e D.M. 21 marzo 1973.**

The VG Series includes stackable ice-cream basins in various sizes and capacities, Carapina box kit and accessories to meet the needs of both producers and distributors. These feature a specially designed easy-grip edge for easy handling and cleaning. Practical for insertion into fridge units and elegant for display in glass units, They are made of 18/10 AISI 304 stainless steel, suitable for storing ice cream according to EU directive n. 1935/2004 and D.M. 21/3/1973.

**1. Coperchio**  
 Cover

**2. Carapina box**  
 Carapina box

**3. Cornice**  
 Frame

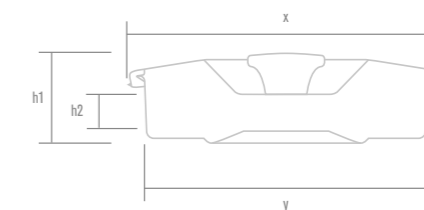
**4. Controcarapine**  
 Carapina tank

**COPERCHIO**  
 Cover

Articolo Item	Diametro Diameter	Dimensioni Size			
		x	y	h1	h2
C03	211	Ø 229	Ø 206,3	63,7	28,1

Misure espresse in mm / Measurements in mm

Nuovo design

New design

Nuova guarnizione in silicone

New silicone rubber

 Idoneo al contatto alimentare  
 Dichiarazione MOCA

 Suitable for food contact (MOCA  
 declaration)

 Maggior spessore per un isolamento  
 più efficace

 Increased thickness for more effective  
 insulation

 Impugnatura ergonomica per facilitare  
 la presa

Ergonomic handle for easy grip

Impilabile

Stackable

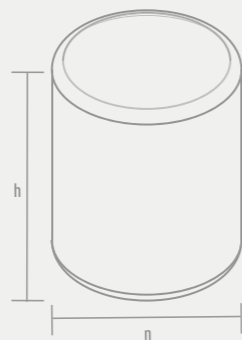

**CARAPINA ANTIROTAZIONE**

Carapina with anti-rotation system

	Articolo Item	Diametro Diameter	Altezza Height
		Ø	H
Con antirotazione With anti-rotation	CPR2024A	200	250
Senza antirotazione Without anti-rotation	CPR2024	200	250

Misure espresse in mm / Measurements in mm

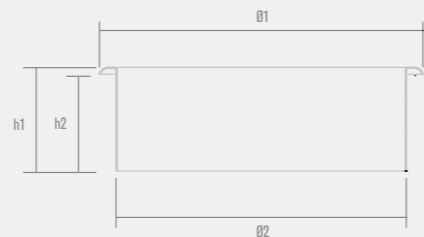

**CORNICE**

Frame

	Articolo Item	Diametro Diameter		Dimensioni Size	
		Ø1	Ø2	A	B
	CF0R	234	210	70/100	5

Misure espresse in mm / Measurements in mm

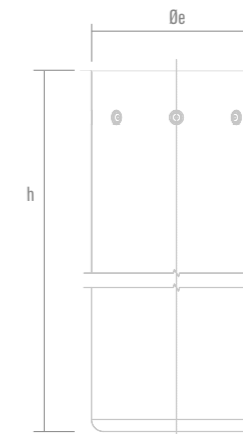

**CONTROCARAPINA**

Carapina tank

	Articolo Item	Diametro Diameter	Altezza Height
		Øe	H
	POZ500A	212	500

Misure espresse in mm / Measurements in mm

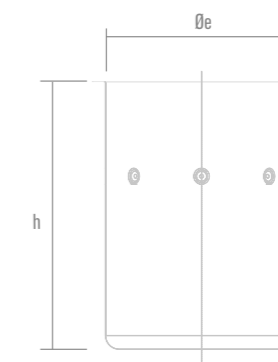

**CONTROCARAPINA**

Carapina tank

	Articolo Item	Diametro Diameter	Altezza Height
		Øe	H
	POZ296A	212	296

Misure espresse in mm / Measurements in mm

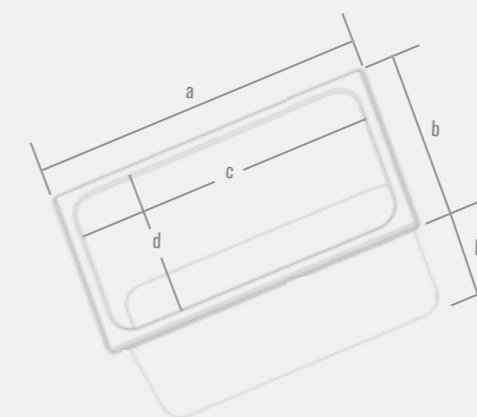

Profondità Depth	Articolo Item	Dim. esterne External size		Dim. interne Internal size		Capacità Capacity	Box
		a	b	c	d		
70	VG3607	360	165	335	145	2,8	20
120	VG3612	360	165	335	145	5,0	20

Misure espresse in mm / Measurements in mm



VG3638

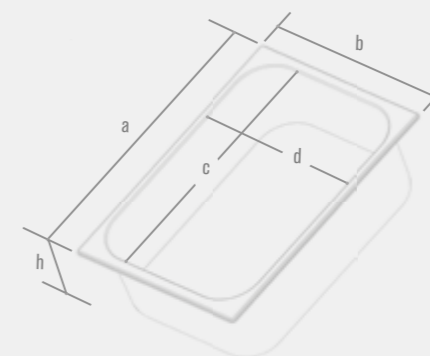

Profondità Depth	Articolo Item	Dim. esterne External size		Dim. interne Internal size		Capacità Capacity	Box
h		a	b	c	d	l.	
80	VG3638	360	250	335	233	5,5	10

Misure espresse in mm / Measurements in mm

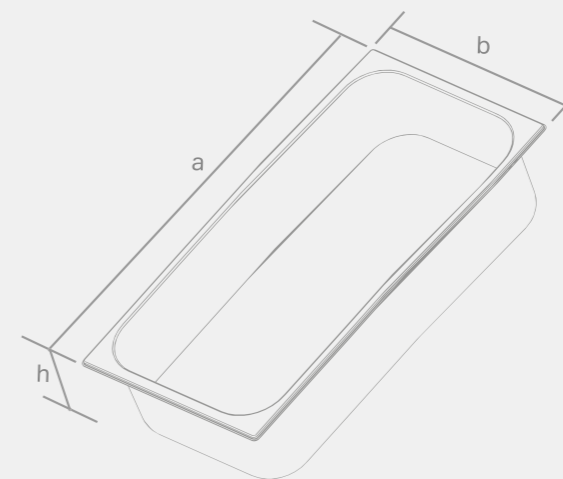

Profondità Depth	Articolo Item	Dim. esterne External size		Foro banco Hole	Capacità Capacity
h		a	b		l.
120	VP27121	270	110	1/2"+3/8"	2,5

Misure espresse in mm / Measurements in mm

## MAESTRI DELL' ACCIAIO

Steel masters



Ronda è azienda leader in ricerca, design e innovazione nella produzione di componenti in acciaio inox per l'arredamento di bar e strutture di ristorazione professionale.

Green da sempre. Ronda è F-GAS compliant. Nel corso del 2019 Ronda ha sostituito il sistema poliuretano espanso HFC a bassa viscosità con il nuovo espandente di quarta generazione HFO Solstice® LBA a basso GWP (1). Questo nuovo sistema è privo di CFC, HCFC e HFC ed è classificato classe F secondo la normativa Europea EN ISO 11925 e UNI EN 13501. Test di laboratorio dimostrano che Solstice® LBA garantisce un miglioramento in termini di efficienza energetica, superiore al 3%, rispetto a sistemi HFC o a schiume a base acqua.

Interamente realizzati in Acciaio AISI 304, il materiale più igienico per eccellenza. Resistente alla corrosione, assenza di qualunque rivestimento protettivo. Compattezza superficiale priva di porosità. Elevata rimozione batterica nei cicli di pulitura

Ronda is a leading company in research, design and innovation for the production of stainless steel units for equipping bars and professional catering facilities.

Green as ever. Ronda is F-GAS compliant. During 2019 Ronda has replaced the HFC low viscosity expanded polyurethane system with the new fourth generation expanding HFO Solstice® LBA with low GWP (1). This new system is CFC, HCFC, and HFC free and class F under European standard EN ISO 11925 and UNI EN 13501. Laboratory tests have demonstrated that Solstice® LBA ensures improved energy efficiency, 3% better than HFC systems or water based foams.

Completely manufactured in AISI 304 stainless steel, the most hygienic material, resistance to corrosion, no protective coating, compact surface without porosity. Elevated bacterial removal during cleaning cycles

## CERTIFICAZIONI AZIENDALI

Company Certifications



I prodotti VG sono idonei al contatto alimentare secondo le norme vigenti

**I prodotti Ronda sono sottoposti a severe prove di affidabilità affinché, oltre alla bellezza e all'ergonomia, possano assicurare la più elevata resistenza e tenuta nel tempo. Tutte le fasi industriali dei prodotti Ronda avvengono sotto rigorosi controlli, dall'arrivo della materia prima fino all'imballaggio. Ronda opera secondo le normative e gli standard internazionali più severi. La Certificazione di Qualità ISO 9001 ottenuta dall'azienda è una garanzia ulteriore dell'affidabilità dei suoi prodotti e delle tecnologie impiegate per costruirli. Gli articoli sono stati provati con riferimento, ove applicabile, alla norma ISO 7170 "Furniture - Storage units - Determination of strength and durability".**

**Ronda utilizza imballi in polistirolo riciclati al 100% forniti da aziende virtuose nel riciclo e recupero del polistirolo con processo circolare ad alta efficienza.**

**Ronda applica, in ottemperanza al Reg.2023/2006/CE, dei protocolli interni per garantire buone pratiche di fabbricazione dei materiali ed oggetti destinati a venire a contatto con gli alimenti.**

L'azienda si riserva il diritto di apportare modifiche e/o migliorie ai prodotti senza preavviso. The company reserves the right to make changes and/or improvements to the products without prior notice.

Ronda products are subjected to very severe testing for reliability so that in addition to looks and ergonomics they also ensure maximum resistance and durability over time. All the industrial steps for Ronda products are conducted under strict controls, all the way from arrival of raw materials to packaging. Ronda operate under the strictest regulations and international standards. The company has been awarded ISO 9001 Quality Certification, providing a further guarantee for the reliability of its products and the production technologies applied. When applicable the items are tested with reference to standard ISO 7170 "Furniture - Storage units - Determination of strength and durability".

Ronda use 100% recycled polystyrene packaging supplied by companies applying high standards for the re-use and recycling of polystyrene in a high efficiency circular process

In compliance with Reg. 2023/2006/EC, Ronda apply internal protocols that ensure good manufacturing practice for materials and items destined to come into contact with foodstuffs.



Via Vegri 83 - 36010 Zanè (VI) Italy - Ph +39 0445 385600 Fax +39 0445 385700  
sales@ronda.it - www.ronda.it